

93LC46/56/66

1K/2K/4K 2.5V Microwire Serial EEPROM

Features:

- Single supply with programming operation down to 2.5V
- Low-power CMOS technology
- 100 μ A typical active read current at 2.5V
- 3 μ A typical standby current at 2.5V
- ORG pin selectable memory configuration
- 128 x 8- or 64 x 16-bit organization (93LC46)
- 256 x 8- or 128 x 16-bit organization (93LC56)
- 512 x 8 or 256 x 16 bit organization (93LC66)
- Self-timed erase and write cycles (including auto-erase)
- Automatic ERAL before WRAL
- Power on/off data protection circuitry
- Industry standard 3-wire serial I/O
- Device status signal during erase/write cycles
- Sequential read function
- 1,000,000 E/W cycles ensured
- Data retention > 200 years
- 8-pin PDIP/SOIC (SOIC in JEDEC standards)
- Temperature ranges supported:
 - Industrial (I): -40°C to +85°C

Description:

The Microchip Technology Inc. 93LC46/56/66 are 1K, 2K and 4K low voltage serial Electrically Erasable PROMs (EEPROM). The device memory is configured as x8 or x16 bits depending on the external logic of levels of the ORG pin. Advanced CMOS technology makes these devices ideal for low power nonvolatile memory applications. The 93LC Series is available in standard 8-pin PDIP and surface mount SOIC packages. The rotated pin-out 93LC46X/56X/66X are offered in the "SN" package only.

Package Types

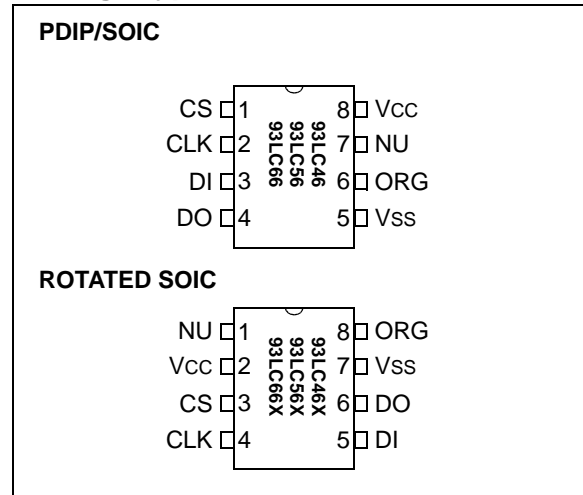

Block Diagram

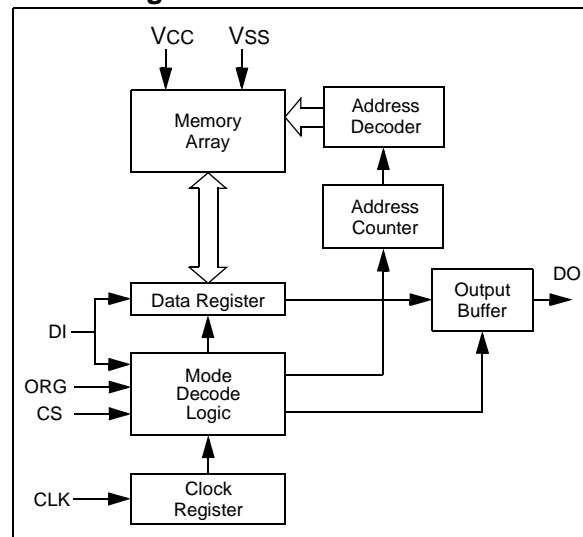

93LC46/56/66

1.0 ELECTRICAL CHARACTERISTICS

Absolute Maximum Ratings^(†)

V _{CC}	6.5V
All inputs and outputs w.r.t. V _{SS}	-0.6V to V _{CC} + 1.0V
Storage temperature	-65°C to +150°C
Ambient temperature with power applied.....	-40°C to +125°C
ESD protection on all pins	≥ 4 kV

† **NOTICE:** Stresses above those listed under "Maximum ratings" may cause permanent damage to the device. This is a stress rating only and functional operation of the device at those or any other conditions above those indicated in the operational listings of this specification is not implied. Exposure to maximum rating conditions for extended periods may affect device reliability.

DC CHARACTERISTICS

DC CHARACTERISTICS			V _{CC} = +2.5V to +5.5V Industrial (I): T _A = -40°C to +85°C				
Param. No.	Sym	Characteristic	Min	Typ	Max	Units	Conditions
D1	V _{IH1}	High-level input voltage	2.0	—	V _{CC} +1	V	V _{CC} ≥ 2.7V
	V _{IH2}		0.7 V _{CC}	—	V _{CC} +1	V	V _{CC} ≥ 2.7V
D2	V _{IL1}	Low-level input voltage	-0.3	—	0.8	V	V _{CC} ≥ 2.7V
	V _{IL2}		-0.3	—	0.2 V _{CC}	V	V _{CC} ≥ 2.7V
D3	V _{OL1}	Low-level output voltage	—	—	0.4	V	I _{OL} = 2.1 mA, V _{CC} = 4.5V
	V _{OL2}		—	—	0.3	V	I _{OL} = 100 μA, V _{CC} = 2.5V
D4	V _{OH1}	High-level output voltage	2.4	—	—	V	I _{OL} = 400 μA, V _{CC} = 4.5V
	V _{OH2}		V _{CC} -0.2	—	—	V	I _{OL} = 100 μA, V _{CC} = 2.5V
D5	I _{LI}	Input leakage current	—	—	±10	μA	V _{IN} = 0.1V to V _{CC}
D6	I _{LO}	Output leakage current	—	—	±10	μA	V _{OUT} = 0.1V to V _{CC}
D7	C _{IN} , C _{OUT}	Pin capacitance (all inputs/outputs)	—	—	7	pF	V _{IN} /V _{OUT} = 0V (Note 1 & 2) T _A = 25°C, F _{CLK} = 1 MHz
D8	I _{CC} write	Operating current	—	—	3	mA	F _{CLK} = 2 MHz, V _{CC} = 5.5V (Note 2)
D9	I _{CC} read		—	—	1	mA	F _{CLK} = 2 MHz, V _{CC} = 5.5V
			—	—	500	μA	F _{CLK} = 1 MHz, V _{CC} = 3.0V
D10	I _{CCS}	—	—	—	μA	F _{CLK} = 1 MHz, V _{CC} = 2.5V	
		—	—	100	μA	CLK = CS = 0V; V _{CC} = 5.5V	
		—	3	—	μA	CLK = CS = 0V; V _{CC} = 3.0V	
							CLK = CS = 0V; V _{CC} = 2.5V
							ORG, DI = V _{SS} or V _{CC}

Note 1: This parameter is tested at T_A = 25°C and F_{CLK} = 1 MHz.

2: This parameter is periodically sampled and not 100% tested.

AC CHARACTERISTICS

AC CHARACTERISTICS			VCC = +2.5V to +5.5V Industrial (I): TA = -40°C to +85°C				
Param. No.	Sym	Characteristic	Min	Typ	Max	Units	Conditions
1	FCLK	Clock frequency	—	—	2	MHz	VCC ≥ 4.5V
			—	—	1	MHz	VCC < 4.5V
2	TCKH	Clock high time	250	—	—	ns	
3	TCKL	Clock low time	250	—	—	ns	
4	TCSS	Chip select setup time	50	—	—	ns	Relative to CLK
5	TCSH	Chip select hold time	0	—	—	ns	Relative to CLK
6	TCSL	Chip select low time	250	—	—	ns	
7	TDIS	Data input setup time	100	—	—	ns	Relative to CLK
8	TDIH	Data input hold time	100	—	—	ns	Relative to CLK
9	TPD	Data output delay time	—	—	400	ns	CL = 100 pF
10	TCZ	Data output disable time	—	—	100	ns	CL = 100 pf (Note 2)
11	Tsv	Status valid time	—	—	500	ns	CL = 100 pF
12	TWC	Program cycle time	—	4	10	ms	Erase/Write mode
13	TEC		—	8	15	ms	ERAL mode (VCC=5V ±10%)
14	TWL		—	16	30	ms	WRAL mode (VCC=5V ±10%)
15	—	Endurance	1M	—	1M	cycles	25°C, VCC = 5.0V, Block mode (Note 3)

Note 1: This parameter is tested at TA = 25°C and FCLK = 1 MHz.

2: This parameter is periodically sampled and not 100% tested.

3: This parameter is not tested but ensured by characterization. For endurance estimates in a specific application, please consult the Total Endurance™ Model which can be obtained from Microchip's web site

FIGURE 1-1: SYNCHRONOUS DATA TIMING

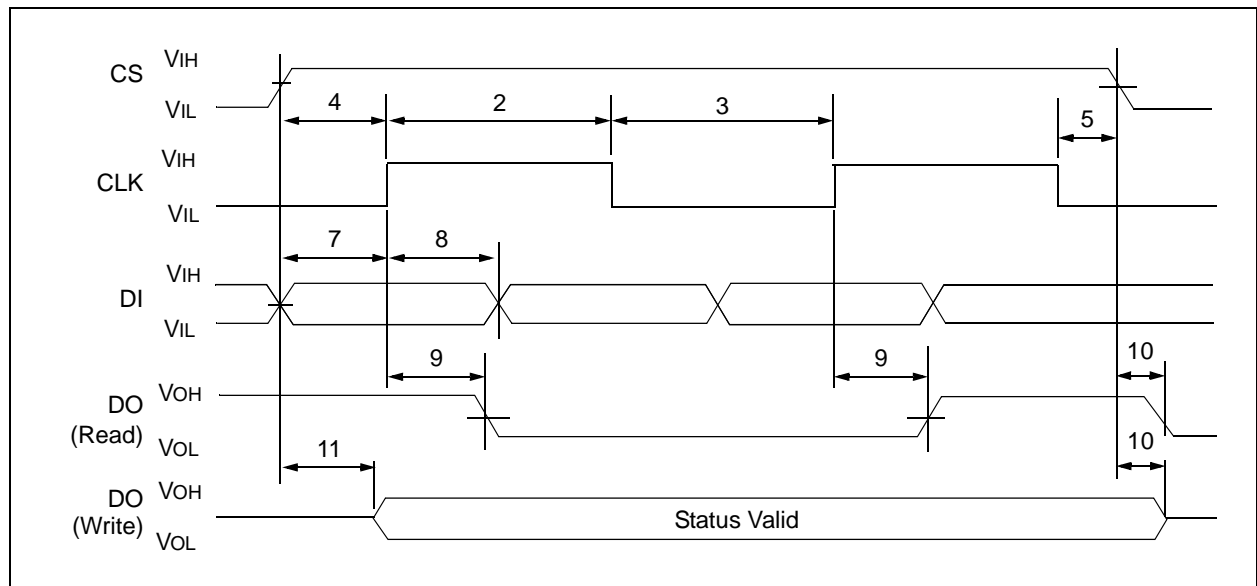

93LC46/56/66

8-Lead Plastic Dual In-line (P) – 300 mil (PDIP)

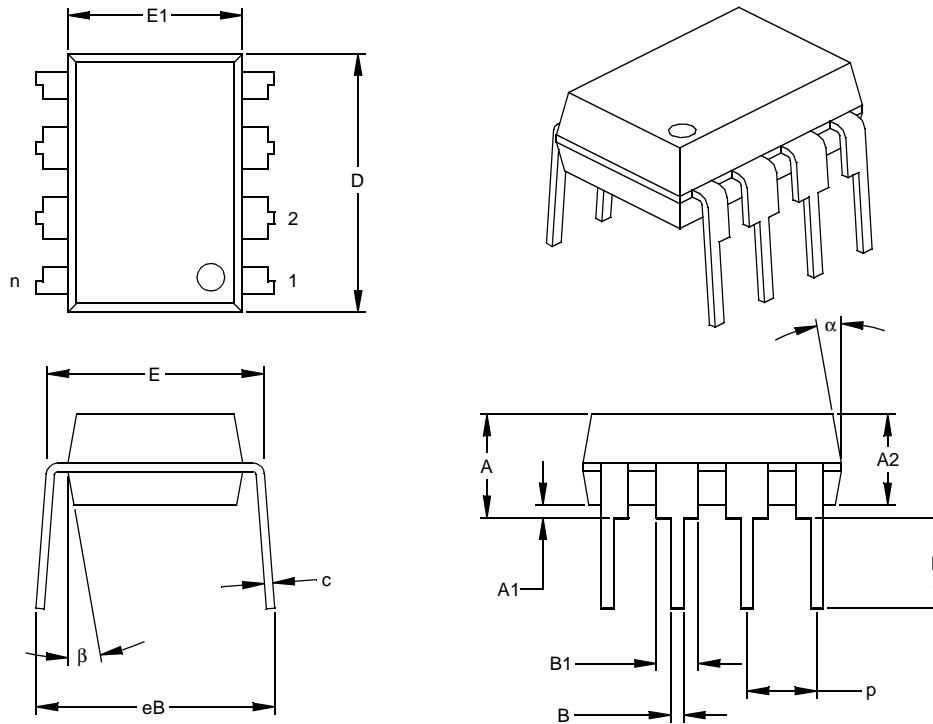

Dimension Limits	Units	INCHES*			MILLIMETERS		
		MIN	NOM	MAX	MIN	NOM	MAX
Number of Pins	n		8			8	
Pitch	p		.100			2.54	
Top to Seating Plane	A	.140	.155	.170	3.56	3.94	4.32
Molded Package Thickness	A2	.115	.130	.145	2.92	3.30	3.68
Base to Seating Plane	A1	.015			0.38		
Shoulder to Shoulder Width	E	.300	.313	.325	7.62	7.94	8.26
Molded Package Width	E1	.240	.250	.260	6.10	6.35	6.60
Overall Length	D	.360	.373	.385	9.14	9.46	9.78
Tip to Seating Plane	L	.125	.130	.135	3.18	3.30	3.43
Lead Thickness	c	.008	.012	.015	0.20	0.29	0.38
Upper Lead Width	B1	.045	.058	.070	1.14	1.46	1.78
Lower Lead Width	B	.014	.018	.022	0.36	0.46	0.56
Overall Row Spacing	§ eB	.310	.370	.430	7.87	9.40	10.92
Mold Draft Angle Top	α	5	10	15	5	10	15
Mold Draft Angle Bottom	β	5	10	15	5	10	15

* Controlling Parameter

§ Significant Characteristic

Notes:

Dimensions D and E1 do not include mold flash or protrusions. Mold flash or protrusions shall not exceed .010" (0.254mm) per side.

JEDEC Equivalent: MS-001

Drawing No. C04-018

PRODUCT IDENTIFICATION SYSTEM

To order or obtain information, e.g., on pricing or delivery, refer to the factory or the listed sales office.

<u>PART NO.</u>	<u>X</u>	<u>/XX</u>	<u>XXX</u>	
Device	Temperature Range	Package	Pattern	
Device	93LC46:	1K 2.5V Microwire Serial EEPROM		
	93LC46X:	1K 2.5V Microwire Serial EEPROM in alternate pinouts (SN package only)		
	93LC46T:	1K 2.5V Microwire Serial EEPROM (Tape and Reel)		
	93LC46XT:	1K 2.5V Microwire Serial EEPROM (Tape and Reel)		
	93LC56:	2K 2.5V Microwire Serial EEPROM		
	93LC56X:	2K 2.5V Microwire Serial EEPROM in alternate pinouts (SN package only)		
	93LC56T:	2K 2.5V Microwire Serial EEPROM (Tape and Reel)		
	93LC56XT:	2K 2.5V Microwire Serial EEPROM (Tape and Reel)		
	93LC66:	4K 2.5V Microwire Serial EEPROM		
	93LC66X:	4K 2.5V Microwire Serial EEPROM in alternate pinouts (SN package only)		
	93LC66T:	4K 2.5V Microwire Serial EEPROM (Tape and Reel)		
	93LC66XT:	4K 2.5V Microwire Serial EEPROM (Tape and Reel)		
Temperature Range	I	= -40°C to +85°C		
Package	P	= Plastic DIP (300 mil body), 8-lead		
	SN	= Plastic SOIC (150 mil body), 8-lead		

Examples:

- a) 93LC46-I/P: 1K, 128x8 or 64x16 Serial EEPROM, PDIP package
- b) 93LC46-I/SN: 1K, 128x8 or 64x16 Serial EEPROM, SOIC package
- c) 93LC46T-I/SN: 1K, 128x8 or 64x16 Serial EEPROM, SOIC package, tape and reel
- d) 93LC46X-I/SN: 1K, 128x8 or 64x16 Serial EEPROM, Rotated SOIC package
- e) 93LC56-I/P: 2K, 256x8 or 128x16 Serial EEPROM, PDIP package
- f) 93LC56-I/SN: 2K, 256x8 or 128x16 Serial EEPROM, SOIC package
- g) 93LC56T-I/SN: 2K, 256x8 or 128x16 Serial EEPROM, SOIC package, tape and reel
- h) 93LC56X-I/SN: 2K, 256x8 or 128x16 Serial EEPROM, Rotated SOIC package
- i) 93LC66-I/P: 4K, 512x8 or 256x16 Serial EEPROM, PDIP package
- j) 93LC66-I/SN: 4K, 512x8 or 256x16 Serial EEPROM, SOIC package
- k) 93LC66T-I/SN: 4K, 512x8 or 256x16 Serial EEPROM, SOIC package, tape and reel
- l) 93LC66X-I/SN: 4K, 512x8 or 256x16 Serial EEPROM, Rotated SOIC package